

TOP VIEW

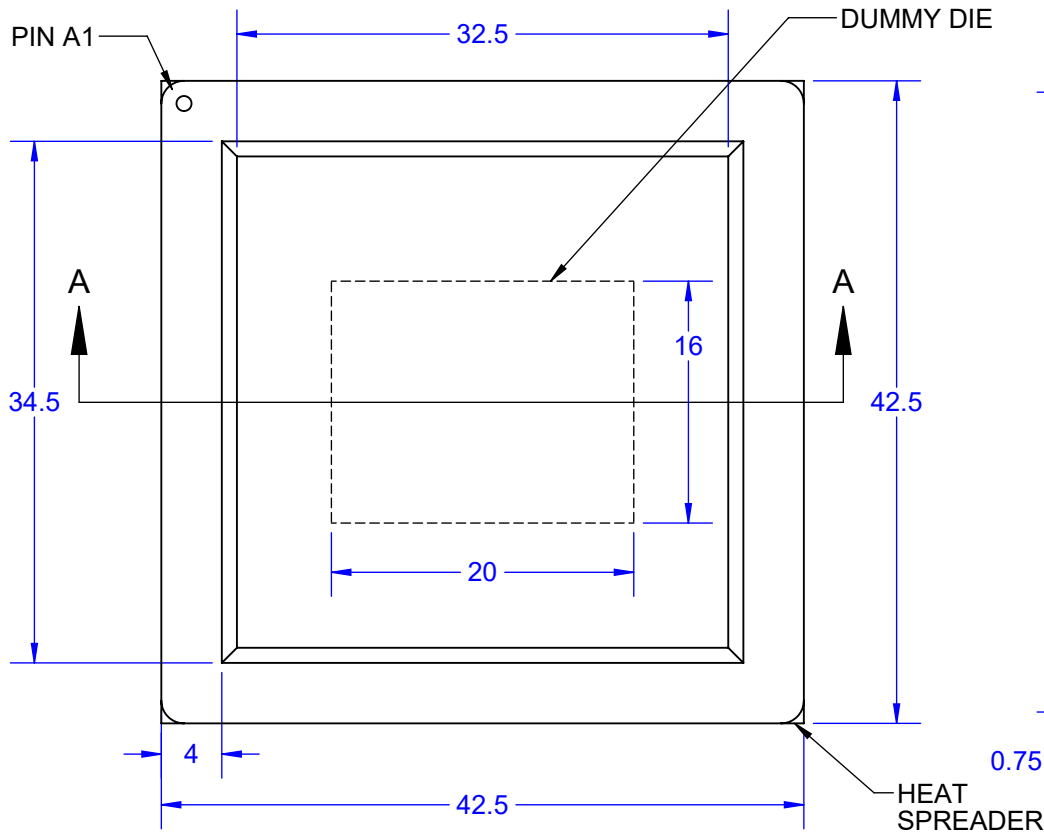

BALL VIEW

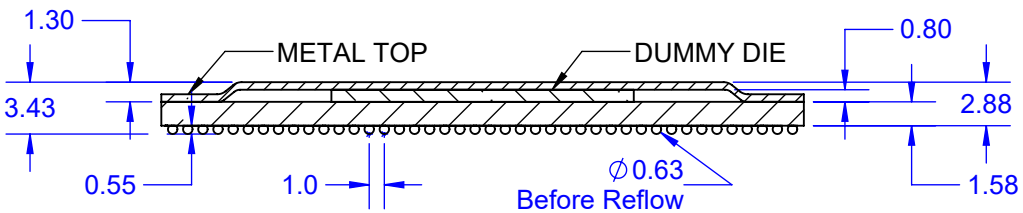
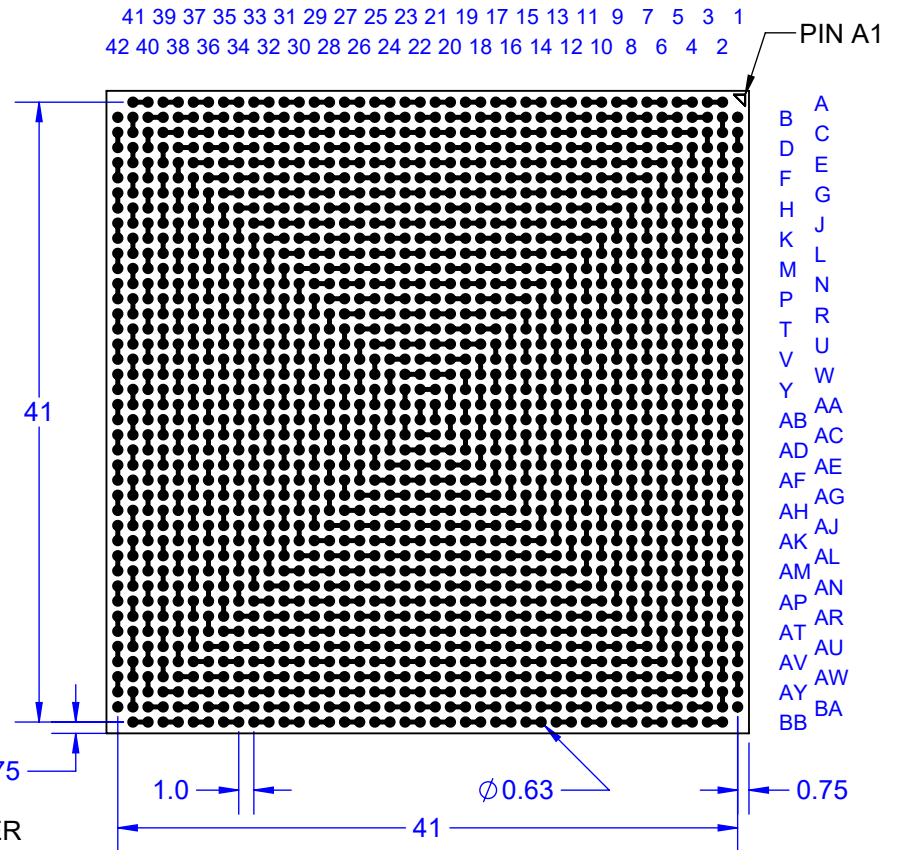

SECTION A-A

- Notes: (Unless Otherwise Specified).
- 1) ALL DIMENSIONS ARE IN MM.
 - 2) SOLDER BALL ALLOY: SEE PART NUMBER TABLE.
 - 3) BALL DIAMETER (BEFORE REFLOW): 0.635mm (25 MIL).
 - 4) SOLDER MASK DEFINED PAD OPENING: 0.508mm (20 MIL).
 - 5) PAD Cu DIAMETER: 0.635mm (25 MIL).
 - 6) SUBSTRATE MATERIAL: FR4 (ALTERNATE BT or Polyimide).
 - 7) DUMMY DIE IS OPTIONAL.
 - 8) DAISY CHAIN PATTERN (SEE PAGE 2).
 - 9) MSL-3 RECOMMENDED BAKING 24 HOURS @ 125°C TO REMOVE MOISTURE PRIOR SOLDERING TO PC BOARD.

PART NUMBER TABLE				
PART NUMBER	BALL ALLOY	BALL ALLOY	RoHS	Si DIE
SBGA1760T1.0C-DC428D	Sn96.5/Ag3.0/Cu0.5	SAC305	YES	YES
SBGA1760T1.0-DC428D	Sn63/Pb37	Sn63	NO	YES

APPROVALS	DATE	TopLine®			
DRAWN T. Au	10/21/17				
ENG M. Hart	10/21/17	TITLE SBGA1760T1.0-DC428D DAISY CHAIN DUMMY			
MFG		SCALE	SIZE	DRAWING NO.	REV
QA		2:1	A	514285	A
CUST		DO NOT SCALE DRAWING			SHEET 1 OF 9
REVISED					

BALL VIEW

41 39 37 35 33 31 29 27 25 23 21 19 17 15 13 11 9 7 5 3 1
42 40 38 36 34 32 30 28 26 24 22 20 18 16 14 12 10 8 6 4 2

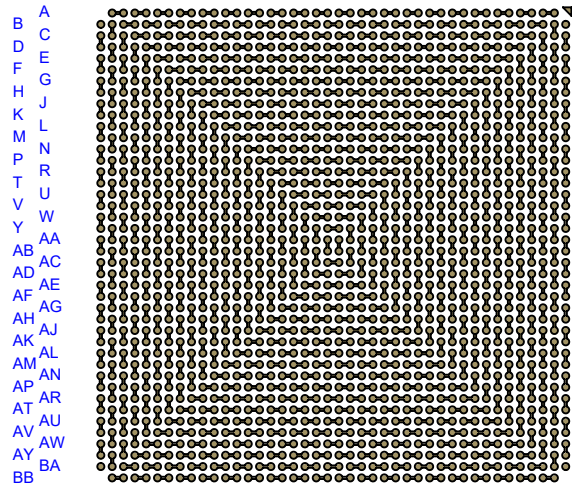

BOTTOM SIDE (TOP X-RAY VIEW)

2 4 6 8 10 12 14 16 18 20 22 24 26 28 30 32 34 36 38 40 42
1 3 5 7 9 11 13 15 17 19 21 23 25 27 29 31 33 35 37 39 41

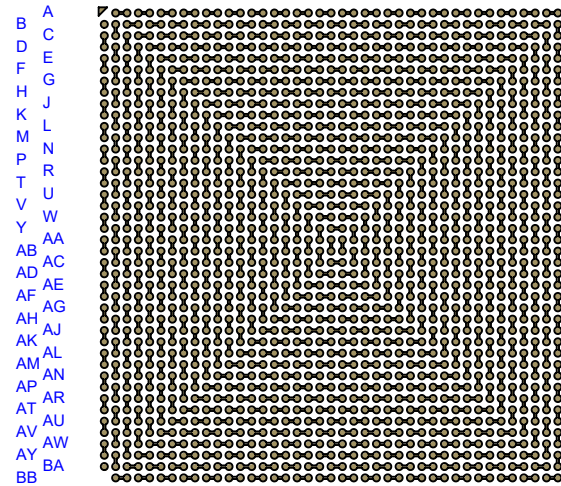

T+ 2 4 6 8 10 12 14 16 18 20 22 24 26 28 30 32 34 36 38 40 42 T-
1 3 5 7 9 11 13 15 17 19 21 23 25 27 29 31 33 35 37 39 41

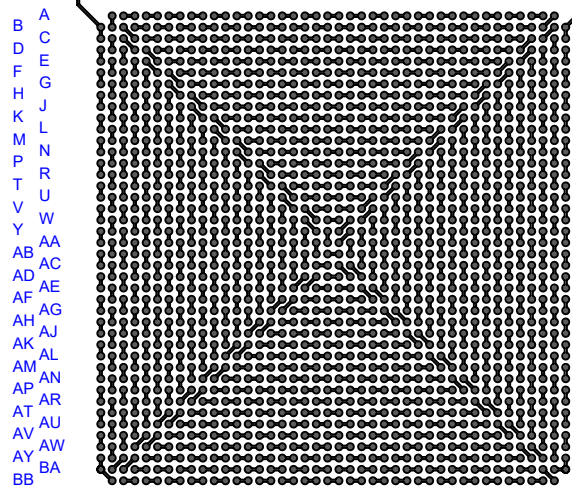

TEST VEHICLE BOARD

T+ 2 4 6 8 10 12 14 16 18 20 22 24 26 28 30 32 34 36 38 40 42 T-
1 3 5 7 9 11 13 15 17 19 21 23 25 27 29 31 33 35 37 39 41

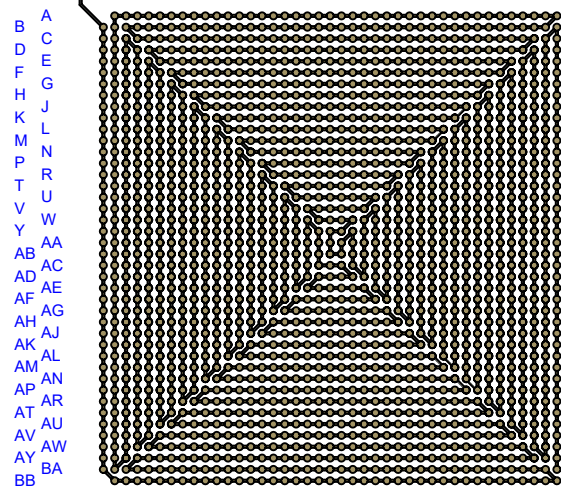

AFTER MOUNTING

Notes:

- 1) PCB BOARD DIMENSIONS ARE PRESENTD ONLY AS A GUIDELINE. DESIGNERS SHOULD USE THEIR OWN EXPERIENCE WHEN DESIGNING PCB.
- 2) PCB Cu BALL PAD DIAMETER 0.635mm [25 MIL].
- 3) PCB DAISY CHAIN TRACING LINE WIDTH 0.204mm [8 MIL].
- 4) SMD (SOLDER MASK DEFINED) PAD OPENING 0.508mm [20 MIL].

TopLine®

TITLE		SBGA1760T1.0-DC428D DAISY CHAIN DUMMY	
SCALE	SIZE	DRAWING NO.	REV
3:2	A	514285	A
DO NOT SCALE DRAWING		SHEET 2 OF 9	

BALL VIEW

42 40 38 36 34 32 30 28 26 24 22 20 18 16 14 12 10 8 6 4 2
 41 39 37 35 33 31 29 27 25 23 21 19 17 15 13 11 9 7 5 3 1

PIN A1



TopLine[®]

TITLE SBGA1760T1.0-DC428D
 DAISY CHAIN DUMMY

SCALE 3.5:1	SIZE A	DRAWING NO. 514285	REV A
----------------	-----------	-----------------------	----------

BOTTOM SIDE (TOP X-RAY VIEW)

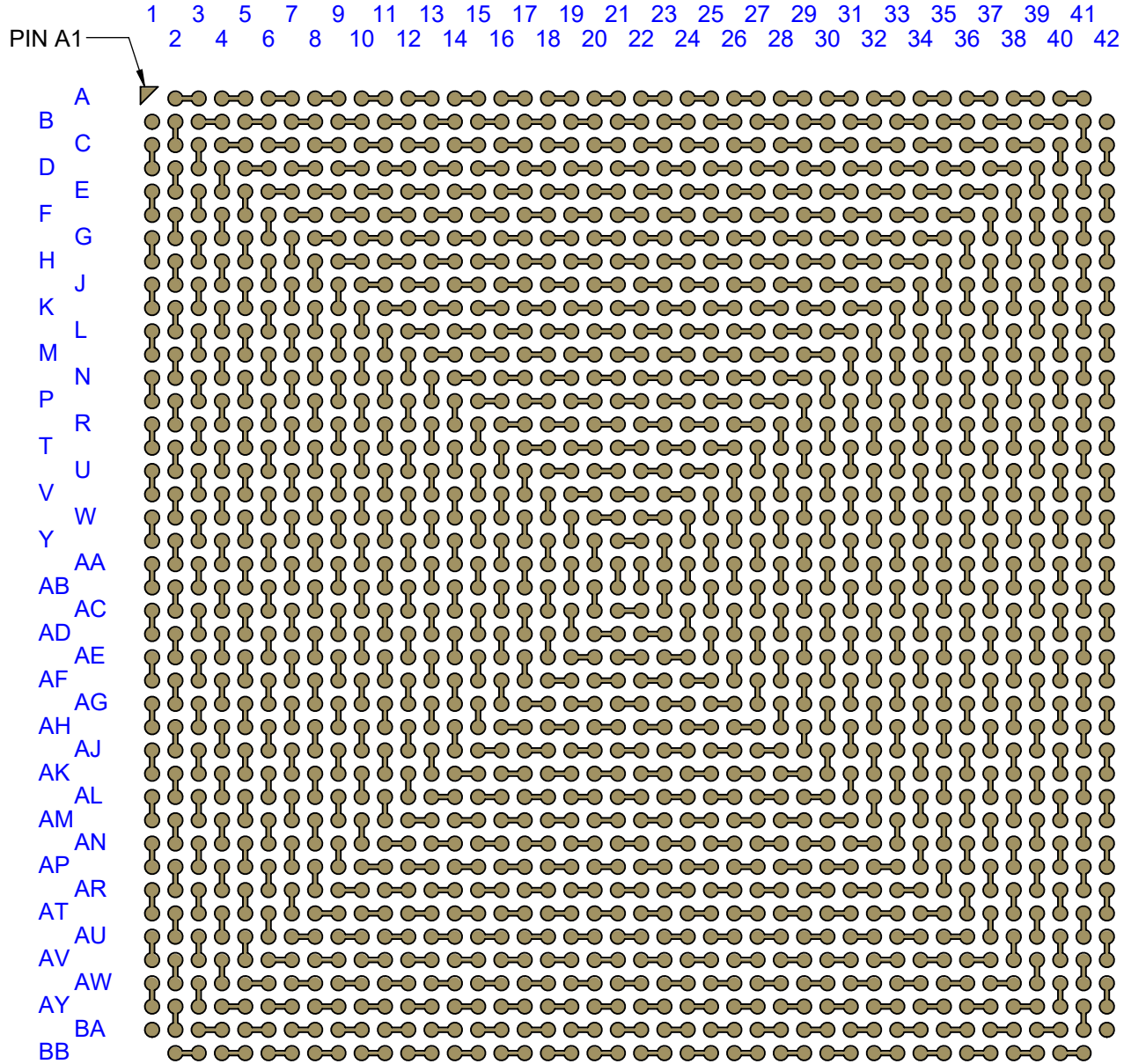

TITLE			
SBGA1760T1.0-DC428D DAISY CHAIN DUMMY			
SCALE	SIZE	DRAWING NO.	REV
3.5:1	A	514285	A
DO NOT SCALE DRAWING			SHEET 4 OF 9

TEST VEHICLE BOARD

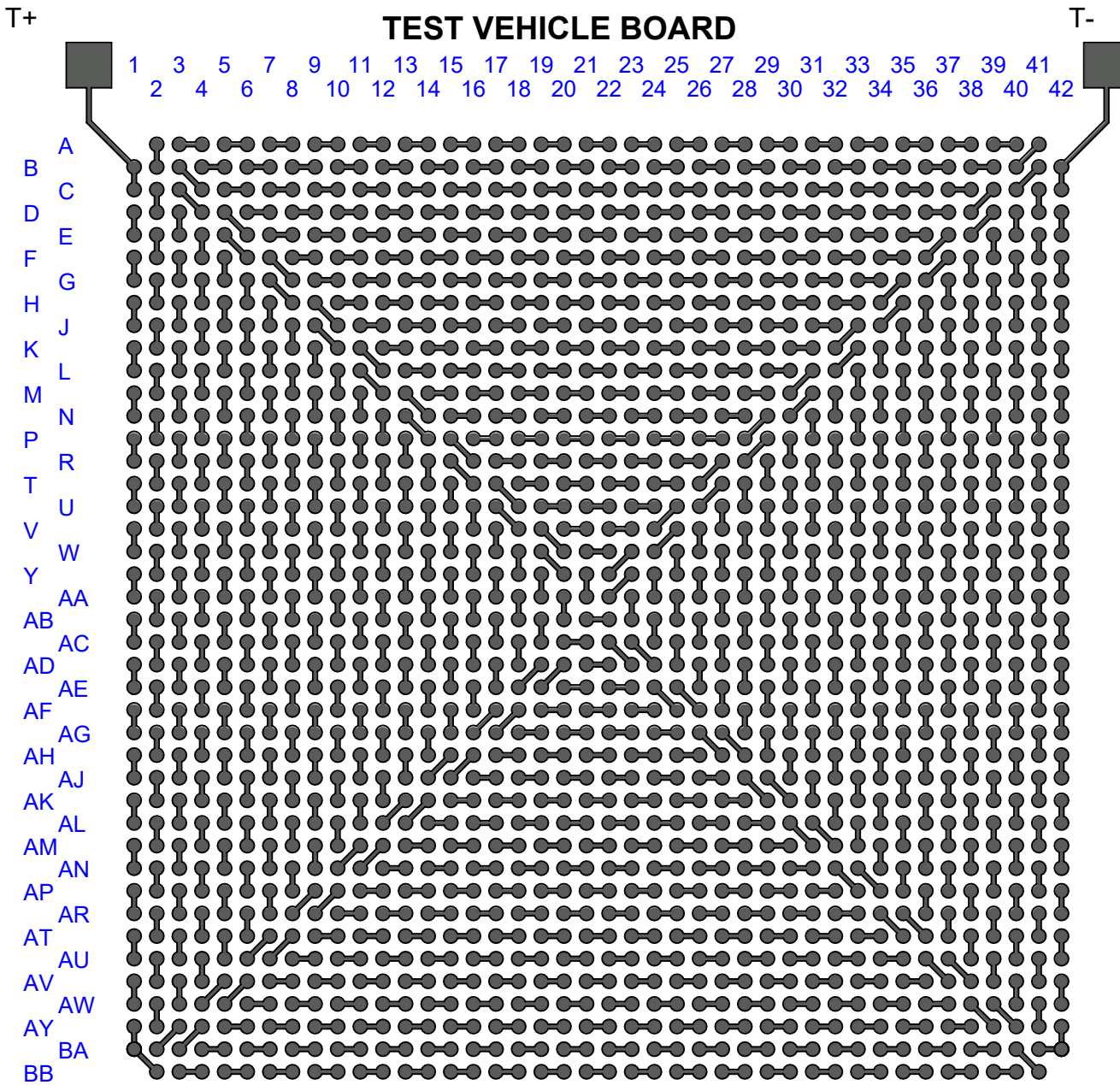

Notes:

- 1) PCB BOARD DIMENSIONS ARE PRESENTD ONLY AS A GUIDELINE. DESIGNERS SHOULD USE THEIR OWN EXPERIENCE WHEN DESIGNING PCB.
- 2) PCB Cu BALL PAD DIAMETER 0.635mm [25 MIL].
- 3) PCB DAISY CHAIN TRACING LINE WIDTH 0.204mm [8 MIL].
- 4) SMD (SOLDER MASK DEFINED) PAD OPENING 0.508mm [20 MIL].

TopLine®			
TITLE		SBGA1760T1.0-DC428D DAISY CHAIN DUMMY	
SCALE	SIZE	DRAWING NO.	REV
3.5:1	A	514285	A
DO NOT SCALE DRAWING			SHEET 5 OF 9

AFTER MOUNTING

T+

T-

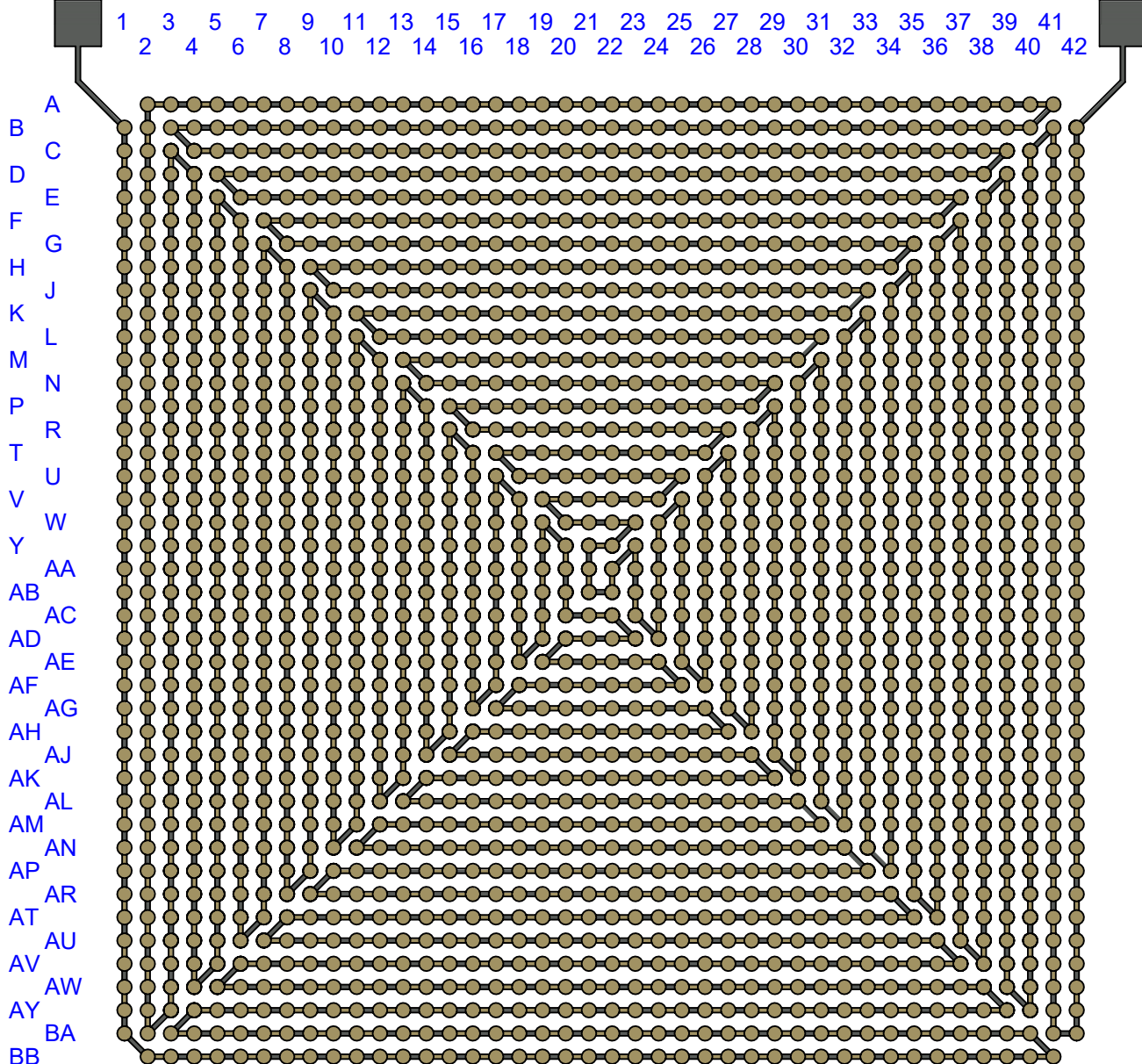

TopLine®

TITLE SBGA1760T1.0-DC428D
DAISY CHAIN DUMMY

SCALE 3.5:1	SIZE A	DRAWING NO. 514285	REV A
----------------	-----------	-----------------------	----------

DO NOT SCALE DRAWING

SHEET 6 OF 9

HEAT SPREADER

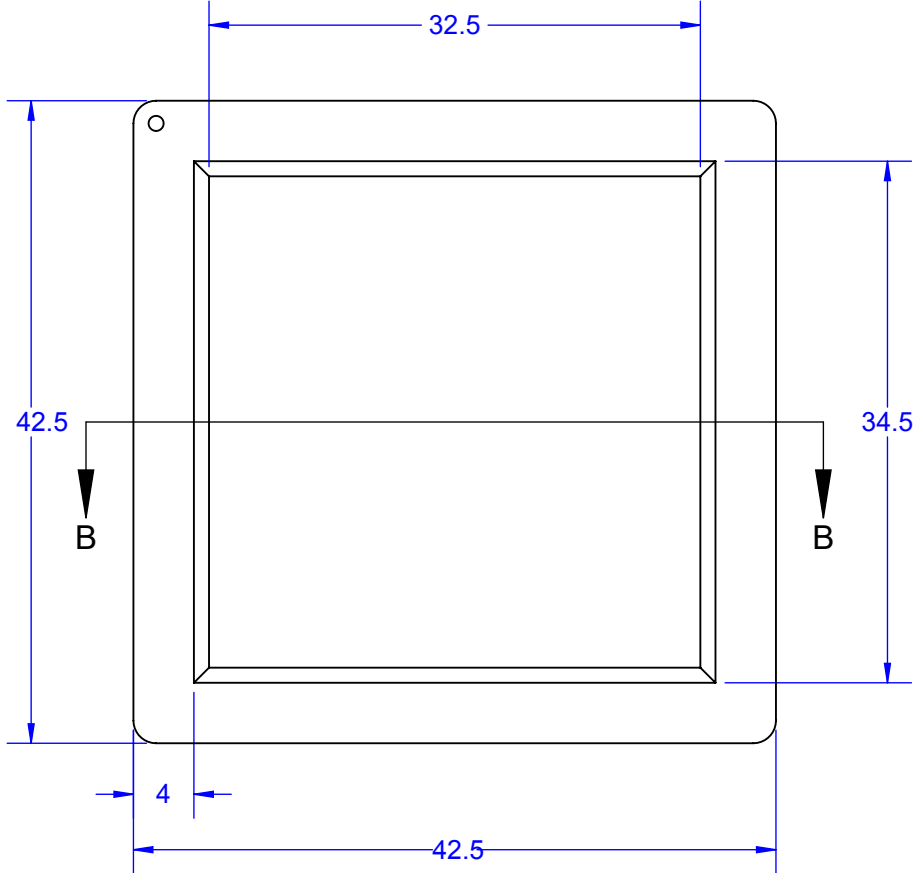

TOP

MODEL



CAVITY

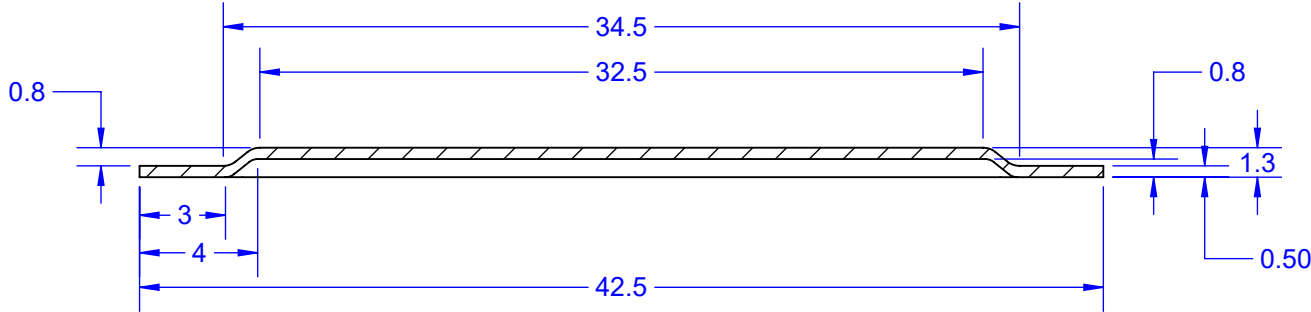

TITLE SBGA1760T1.0-DC428D
DAISY CHAIN DUMMY

SCALE 2:1	SIZE A	DRAWING NO. 514285	REV A
--------------	-----------	-----------------------	----------

MODEL

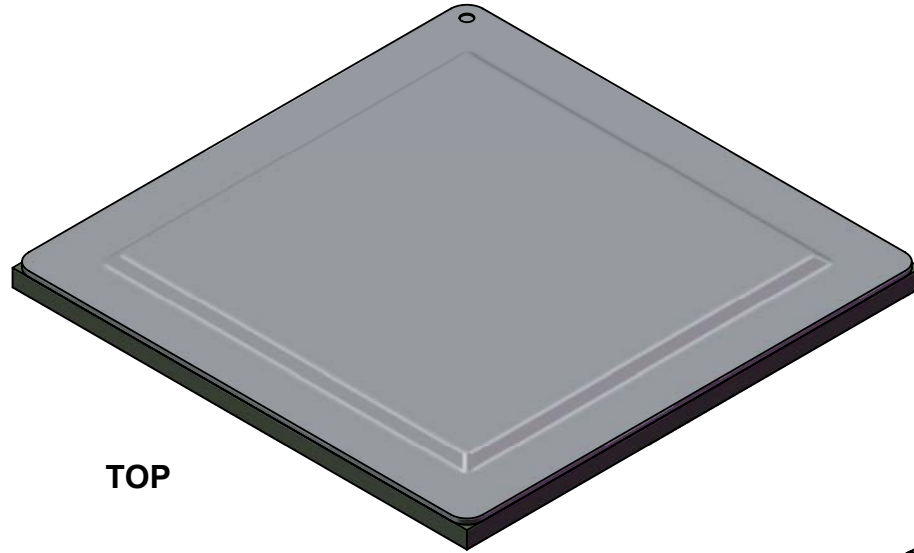

TOP

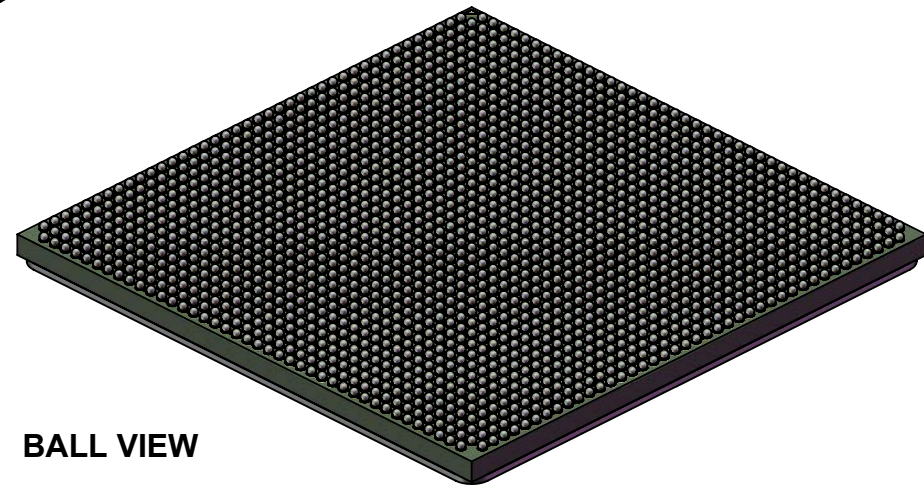

BALL VIEW

TopLine[®]

TITLE SBGA1760T1.0-DC428D
DAISY CHAIN DUMMY

SCALE 2:1	SIZE A	DRAWING NO. 514285	REV A
--------------	-----------	-----------------------	----------

DO NOT SCALE DRAWING

SHEET 8 OF 9

BOTTOM SOLDER MASK (RIGHT READING)

44 42 40 38 36 34 32 30 28 26 24 22 20 18 16 14 12 10 8 6 4 2
43 41 39 37 35 33 31 29 27 25 23 21 19 17 15 13 11 9 7 5 3 1

A
B
C
D
E
F
G
H
J
K
L
M
N
P
R
T
U
V
W
Y
AA
AB
AC
AD
AE
AF
AG
AH
AJ
AK
AL
AM
AN
AP
AR
AT
AU
AV
AW
AY
BA
BB
BC
BD

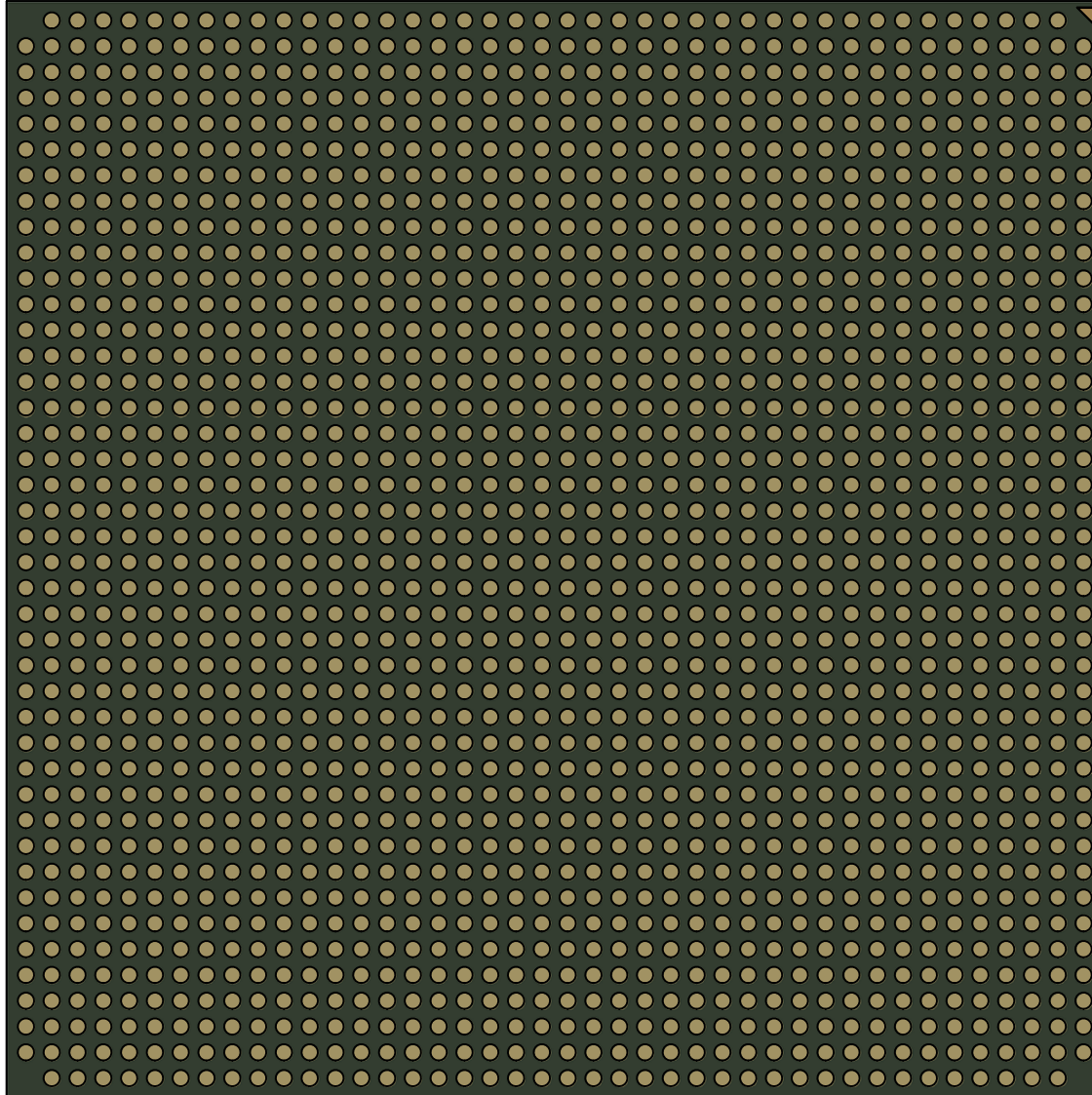

TopLine®			
TITLE SBGA1760T1.0-DC428D DAISY CHAIN DUMMY			
SCALE 3.75:1	SIZE A	DRAWING NO. 514285	REV A
DO NOT SCALE DRAWING		SHEET 9 OF 9	